

CHUTES ENTERPRISES
OFFICE: 1011 WESTWOOD AVENUE
 718-494-2247 FAX 718-494-2257 CELL # 917-647-1410
FACTORY: 28 NORTH 14TH STREET, P.O. BOX 7323, NEWARK, NJ 07107
 973-677-7155 FAX 972-677-2166 TOLL FREE # 855-677-7155

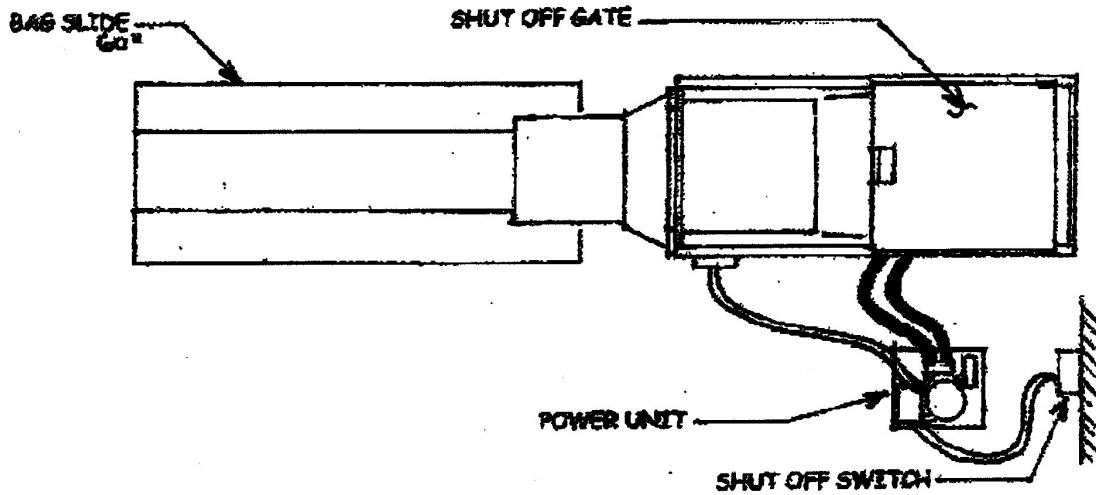
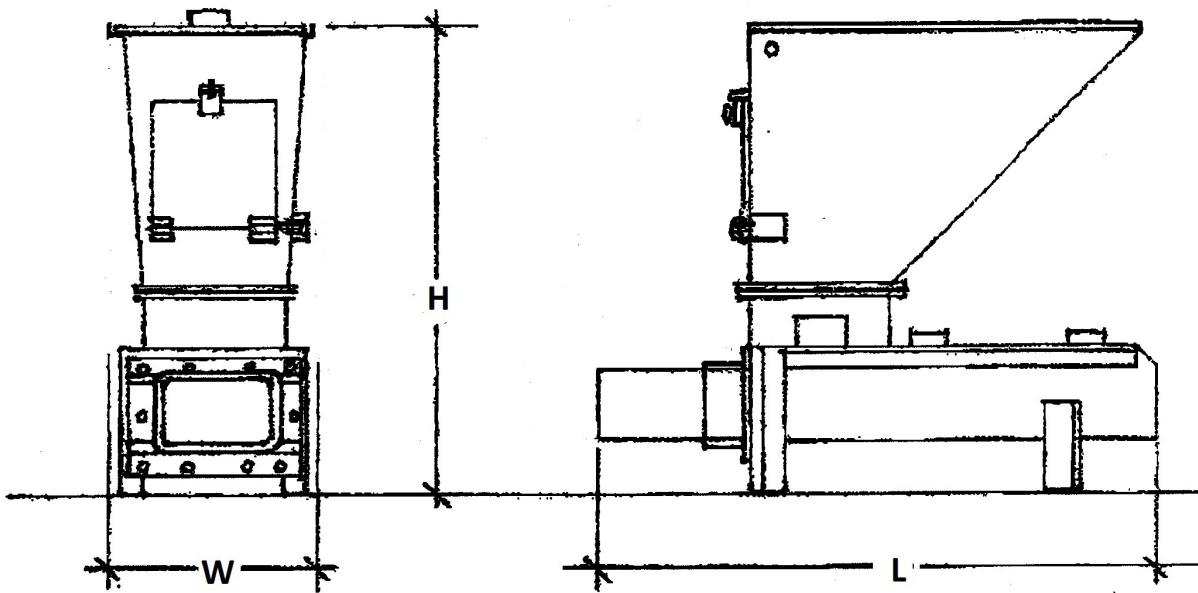

COMPACTOR DIMENSIONS

MODEL	H*	W	L
CE-150	71"	26"	80"
CE-350	73"	27"	90"

* Compactor height may be adjusted to accommodate field conditions or the mounting of recycling diverter by adjusting hopper height.